



TAC
1354 Clifford Avenue
P. O. Box 2940
Loves Park, IL 61132-2940
www.tac.com

MF-22xx3

Floating Valve Actuator General Instructions

Application

The MF-22XX3 Series Floating Valve Actuator is a non-spring return actuator used with floating DDC controllers and standard 1/2" to 1-1/4" two-way and three-way valve bodies for control of heating and cooling coils. Typical applications include VAV terminals with reheat coils, fan coil units, and unit ventilators. Certain models are thermally isolated for use with chilled fluids.

Features

- Floating actuator controlled by DDC controller with contact or Triac output or SPDT center off controller (drive open-hold-drive closed)
- 45 pounds (200 newtons) of output force with automatic load limit for self-adjusting travel and long motor life
- Synchronous motor for consistent timing
- Manual override with automatic release
- Optional feedback potentiometer available for precision control or position indication
- Integral linkage for all standard 1/2" to 1-1/4" TAC two-way stem-up open and three-way valve bodies for a wide variety of applications
- Compact size for application flexibility
- Rugged construction with die cast housing

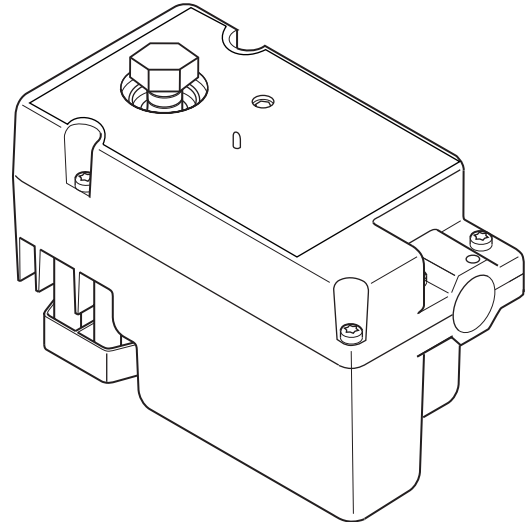

MF-223X3

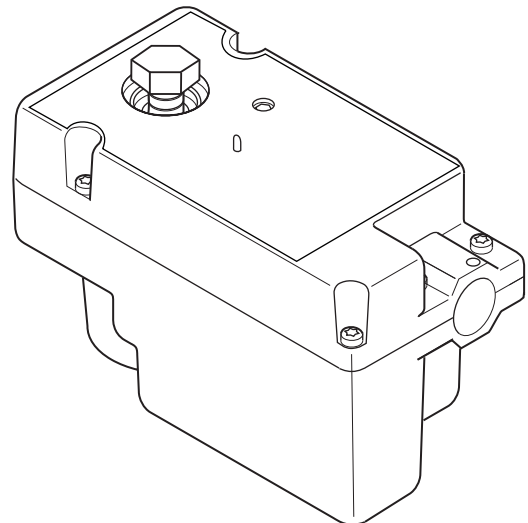

MF-22203

Applicable Literature

F-Number	Description	Audience	Purpose
F-23638	TAC Cross-Reference Guide	<ul style="list-style-type: none"> – Sales Personnel – Application Engineers – Service Personnel 	Provides a listing of TAC HVAC component products to assist in the selection of product replacement. The components are cross referenced to compatible older components and/or competitive components.
F-21683	TAC Reference Manual	<ul style="list-style-type: none"> – Sales Personnel – Application Engineers – Installers – Service Personnel – Start-up Technicians 	A collection of currently published component General Instruction literature in a two volume format.
F-21335	TAC Application Manual	<ul style="list-style-type: none"> – Application Engineers – Service Personnel 	Provides theory of operations for numerous HVAC applications.
F-26262	VF-7XXX Series Valve Selection Guide for the MF-22XX3 Actuator	<ul style="list-style-type: none"> – Sales Personnel – Application Engineers – Service Personnel 	Provides a listing of VF-7XXX Series valve bodies and their characteristics as used with the MF-22XX3 actuator. This document assists in the selection of appropriate valve body for product ordering or replacement.
F-26075	VB-7213 Series 1/2" to 2" Screwed NPT Stem Up Open, Two-Way Valves General Instructions	<ul style="list-style-type: none"> – Sales Personnel – Application Engineers – Installers – Service Personnel – Start-up Technicians 	Describes the VB-7213 Series valve features, specifications, and possible application. Also provides step-by-step mounting, installation, and checkout instructions.
F-25675	VB-7214 Series 1/2" to 2" Union Sweat, Solder Joint Stem Up Open, Two-Way Valves General Instructions	<ul style="list-style-type: none"> – Sales Personnel – Application Engineers – Installers – Service Personnel – Start-up Technicians 	Describes the VB-7214 Series valve features, specifications, and possible application. Also provides step-by-step mounting, installation, and checkout instructions.
F-26077	VB-7215 Series 15 mm to 50 mm Screwed Rp Stem Up Open, Two-Way Valves General Instructions	<ul style="list-style-type: none"> – Sales Personnel – Application Engineers – Installers – Service Personnel – Start-up Technicians 	Describes the VB-7215 Series valve features, specifications, and possible application. Also provides step-by-step mounting, installation, and checkout instructions.
F-24388	VB-7253 Series 1/2" to 2" Screwed NPT Stainless Steel Trim with Teflon Disc Stem Up Open, Two-Way Valves General Instructions	<ul style="list-style-type: none"> – Sales Personnel – Application Engineers – Installers – Service Personnel – Start-up Technicians 	Describes the VB-7253 Series valve features, specifications, and possible application. Also provides step-by-step mounting, installation, and checkout instructions.
F-24390	VB-7273 Series 1/2" to 2" Screwed NPT Stainless Steel Trim Stem Up Open, Two-Way Valves General Instructions	<ul style="list-style-type: none"> – Sales Personnel – Application Engineers – Installers – Service Personnel – Start-up Technicians 	Describes the VB-7273 Series valve features, specifications, and possible application. Also provides step-by-step mounting, installation, and checkout instructions.
F-24392	VB-7312 Series 5/8" O.D., 45° SAE Flared Three-Way Mixing Valves General Instructions	<ul style="list-style-type: none"> – Sales Personnel – Application Engineers – Installers – Service Personnel – Start-up Technicians 	Describes the VB-7312 Series valve features, specifications, and possible application. Also provides step-by-step mounting, installation, and checkout instructions.
F-26074	VB-7313 Series 1/2" to 2" Screwed NPT Three-Way Mixing Valves General Instructions	<ul style="list-style-type: none"> – Sales Personnel – Application Engineers – Installers – Service Personnel – Start-up Technicians 	Describes the VB-7313 Series valve features, specifications, and possible application. Also provides step-by-step mounting, installation, and checkout instructions.
F-24394	VB-7314 Series 1/2" to 2" Union Sweat, Solder Joint, Three-Way Mixing Valves General Instructions	<ul style="list-style-type: none"> – Sales Personnel – Application Engineers – Installers – Service Personnel – Start-up Technicians 	Describes the VB-7314 Series valve features, specifications, and possible application. Also provides step-by-step mounting, installation, and checkout instructions.
F-26078	VB-7315 Series 15 mm to 50 mm Screwed Rp Three-Way Mixing Valves General Instructions	<ul style="list-style-type: none"> – Sales Personnel – Application Engineers – Installers – Service Personnel – Start-up Technicians 	Describes the VB-7315 Series valve features, specifications, and possible application. Also provides step-by-step mounting, installation, and checkout instructions.

F-Number	Description	Audience	Purpose
F-24396	VB-7332 Series 5/8" O.D. 45° SAE Flared Three-Way Sequencing Valves General Instructions	<ul style="list-style-type: none"> - Sales Personnel - Application Engineers - Installers - Service Personnel - Start-up Technicians 	Describes the VB-7332 Series valve features, specifications, and possible application. Also provides step-by-step mounting, installation, and checkout instructions.
F-26261	AV-642 Valve Linkage Kit for Controlli Valve Bodies	<ul style="list-style-type: none"> - Sales Personnel - Application Engineers - Installers - Service Personnel - Start-up Technicians 	Describes the AV-642 valve linkage kit features, specifications, and possible application. Also provides step-by-step mounting, installation, and checkout instructions.

SPECIFICATIONS

Inputs

Control Signal:

SPDT Center Off (Floating) Control Contacts or Two SPST Control Contacts,
Minimum rating of 250 mA @ 24 Vac inductive load.

Two Triacs, DDC output must be able to switch 250 mA (24 VA) inductive load (150 Vac minimum).

Power Input: See Table-1.

Connections: 4 foot (1.2 m) color coded 18 AWG, plenum cable rated for UL and IEC-332-3 category C.

Outputs

Position Feedback Signal: 15K ohm nominal potentiometer. See Table-1 and Figure-7.

Connections, 4 foot (1.2 m) color coded 18 AWG, plenum cable rated for UL.

Mechanical:

Force, 45 pounds (200 N) minimum with automatic load limit. See Table-3.

Stroke, Up to 9/16" (14.3 mm) maximum, self-adjusting.

Timing, See Table-1.

Manual Operator: Allows actuator to be manually set at any position upon loss of power. Releases automatically when power is restored.

Environment

Ambient Temperature Limits:

Shipping and Storage, -40 to 160°F (-40 to 71°C).

Operating,

Minimum 40°F (4°C).

Maximum See Table-2.

Fluid Temperature Limits: See Table-2.

Humidity: 5 to 95% RH, *non-condensing*. See Table-2 for dew point temperature.

Location: NEMA Type 1.

Enclosure Protection Class: Designed to meet IP31 Class, according to EN 60529, BS EN 60529.

Agency Listings

UL 873: Underwriters Laboratories (File # E9429 Category Temperature-Indicating and Regulating Equipment).

CUL: Certified for use in Canada by Underwriters Laboratories. Canadian Standard C22.2 No. 24-93.

European Community: EMC Directive (89/336/EEC).

Table-1 Actuator Model Chart.

Part Number	Application	Actuator Power Input			Feedback	Typical Timing in Sec. @ 75°F for 1/2" (12.7mm) Stroke		Max. Stroke in in. (mm)	
		Voltage (+20%, -15%)	Hz	VA		15K ¾ Pot. ^a	60 Hz		50 Hz
MF-22203	Hot Water ^b Steam ^c	24 (Class 2 Power Supply)	50	60	1.5	No	126 ±30 sec.	151 ±30 sec.	9/16 (14.3)
MF-22303	Chilled/Hot Water					No			
MF-22323	Steam ^c					Yes			

^a Running or manually adjusting the actuator before it is mounted to a valve changes the potentiometer setting and could also cause damage.

^b Do not use MF-22203 models in chilled water applications.

^c Refer to Table-2 for maximum allowable temperature.

Table-2 Restrictions on Ambient Temperature for Valve Actuators.

Part Number	Temperature of Media in the Valve Body (Check Rating of the Valve)		Maximum Actuator Ambient Temperature	Dew Point Temperature
	Minimum	Maximum		
MF-22203	70°F (21°C)	281°F (138°C)	115°F (46°C)	Non-condensing ^a
		220°F (104°C)	140°F (60°C)	
MF-22303 MF-22323	40°F ^b (4°C)	281°F (138°C)	115°F (46°C)	88°F Dew Point maximum with 40°F fluid (31°C Dew Point maximum with 4°C fluid) ^b
		220°F (104°C)	140°F (60°C)	

^a Do not use MF-22203 models in chilled water applications.

^b The dew point temperature cannot be more than 48°F (26.7°C) above the fluid temperature.

Table-3 Close-off Pressure Ratings.

Valve Body Part Number ^a	Valve Sizes	Close-off Pressure ^b Nominal
Two-Way Valves VB-7211 VB-7212 VB-7213 VB-7214 VB-7215 ^c	1/2"	130
	3/4"	80
	1"	40
	1-1/4"	25
Three-Way Mixing Valves VB-7312 VB-7313 VB-7314 VB-7315 ^c	1/2"	130
	3/4"	80
	1"	40
	1-1/4"	25

^a MF-22XX3 Actuators may also be used with VB-9000 Valves. Refer to **TAC Valve Catalog, F-27414**, for available valves.

^b Close-off ratings describe only the differential pressure which the actuator can close with adequate seating force.

Consult valve body specifications for other limitations, see "Applicable Literature" for document listing.

^c Metric thread 15 to 32 mm (Rp 1/2 to Rp 1-1/4).

ACCESSORIES

- AV-641 Valve linkage kit (replacement parts only, order separately, see F-26588)
- AV-642 Four-way valve linkage kit for Controlli valve bodies (see F-26261)
- AV-644 Valve linkage kit (included with MF-22XX3 actuator) (see Figure-9)
- FRAC-255 Metric male 20 mm conduit fitting (m20 x 1.5 - 8g) 11 mm nominal thread length

Note: If the actuator drive screw (Figure-10) has a round opening in the center, then the center section of the stem extension should also be round to match. AV-641 Valve Linkage Kit contains the round stem extension. (Valve/actuator assemblies using the AV-641 valve linkage kit are assembled similar to the AV-644 illustration shown in Figure-9).

TYPICAL APPLICATION (wiring diagrams)

Basic Actuator

Figure-1 and Figure-2 illustrate a typical wiring diagram, Figure-3 through Figure-6 illustrate wiring configurations using multiple MF-22XX3 actuators with one controller.

Caution:

- One SPDT output or two SPST outputs can control one actuator. This actuator features automatic load limiting that switches off the motor. Each actuator must have its own separate controller output or relay/triacs.
- If two SPST contacts are used, insure that both are not closed at the same time. Damage to the motor will result if this happens.
- If two triacs are used to control one actuator, insure that only one triac closes at a time.
- Controller hysteresis settings of 5% or greater are required for optimum actuator life.

CAUTION: Each actuator must have its own separate controller output or relay.

1 For actuator models manufactured prior to date code 990X (e.g. 9904, 9905, etc.), see Table 4 for wire color and numbers.

2 Two-position 3 wire control is possible by use of a snap acting Form-C controller output.

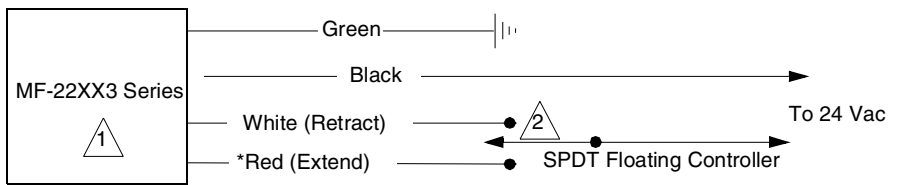

Figure-1 Basic Wiring Diagram with SPDT Floating Control.

CAUTION: Each actuator must have its own separate controller output or relay.

1 For actuator models manufactured prior to datecode 990X (e.g. 9904, 9905, etc.), see Table 4 for wire color and numbers.

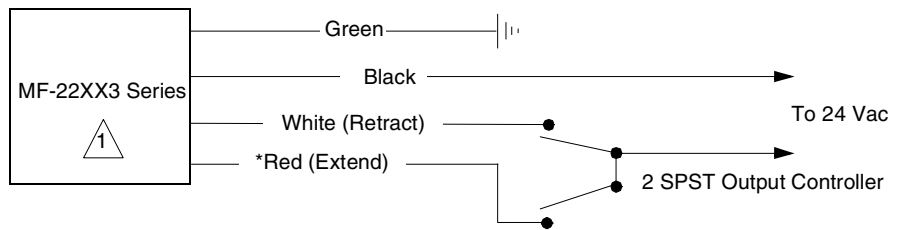

Figure-2 Basic Wiring Diagram with Two SPST Control Contacts.

CAUTION: Each actuator must have its own separate controller output or relay.

1 For actuator models manufactured prior to date code 990X (e.g. 9904, 9905, etc.), see Table 4 for wire colors and numbers.

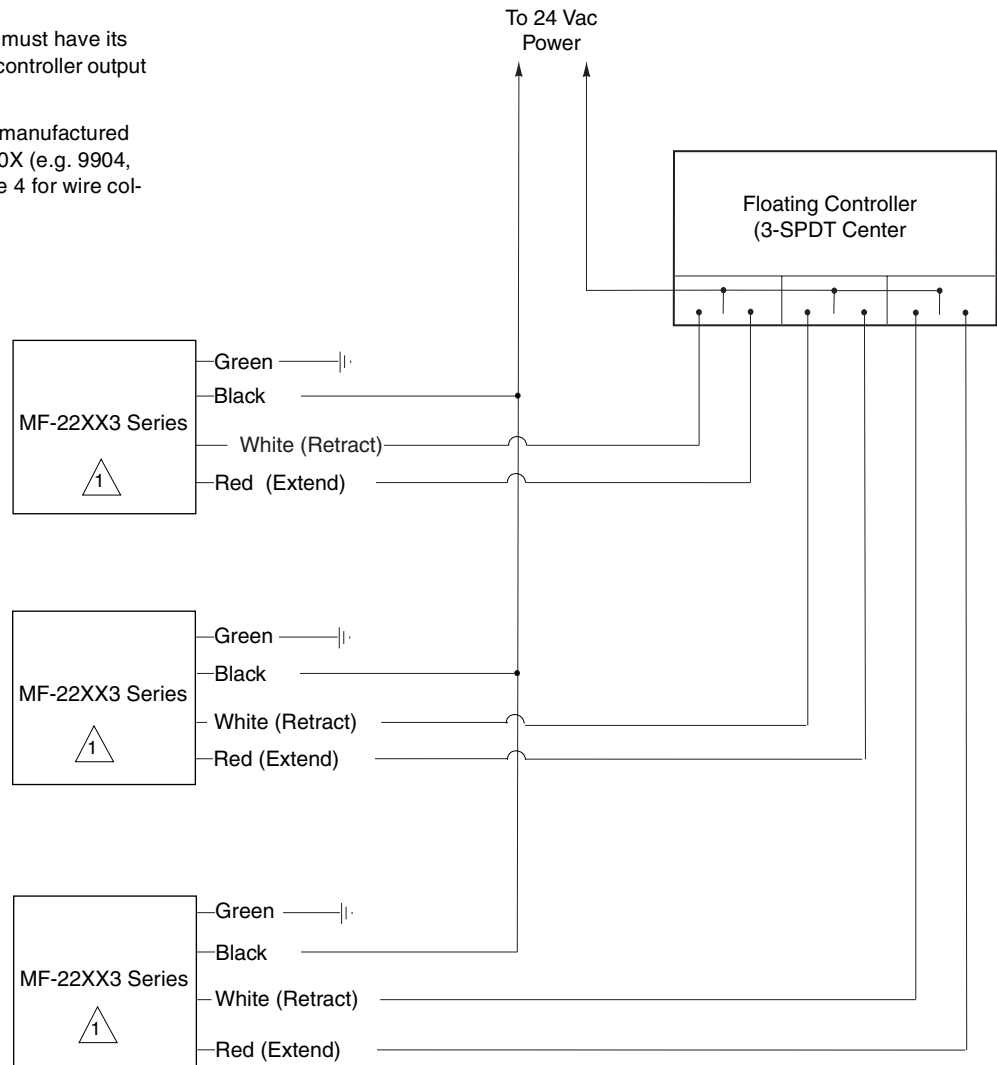

Figure-3 Typical Wiring Configuration with 3-SPDT Center Off Floating Controller.

CAUTION: Each actuator must have its own separate controller output or relay.

1 For actuator models manufactured prior to date code 990X (e.g. 9904, 9905, etc.), see Table 4 for wire colors and numbers..

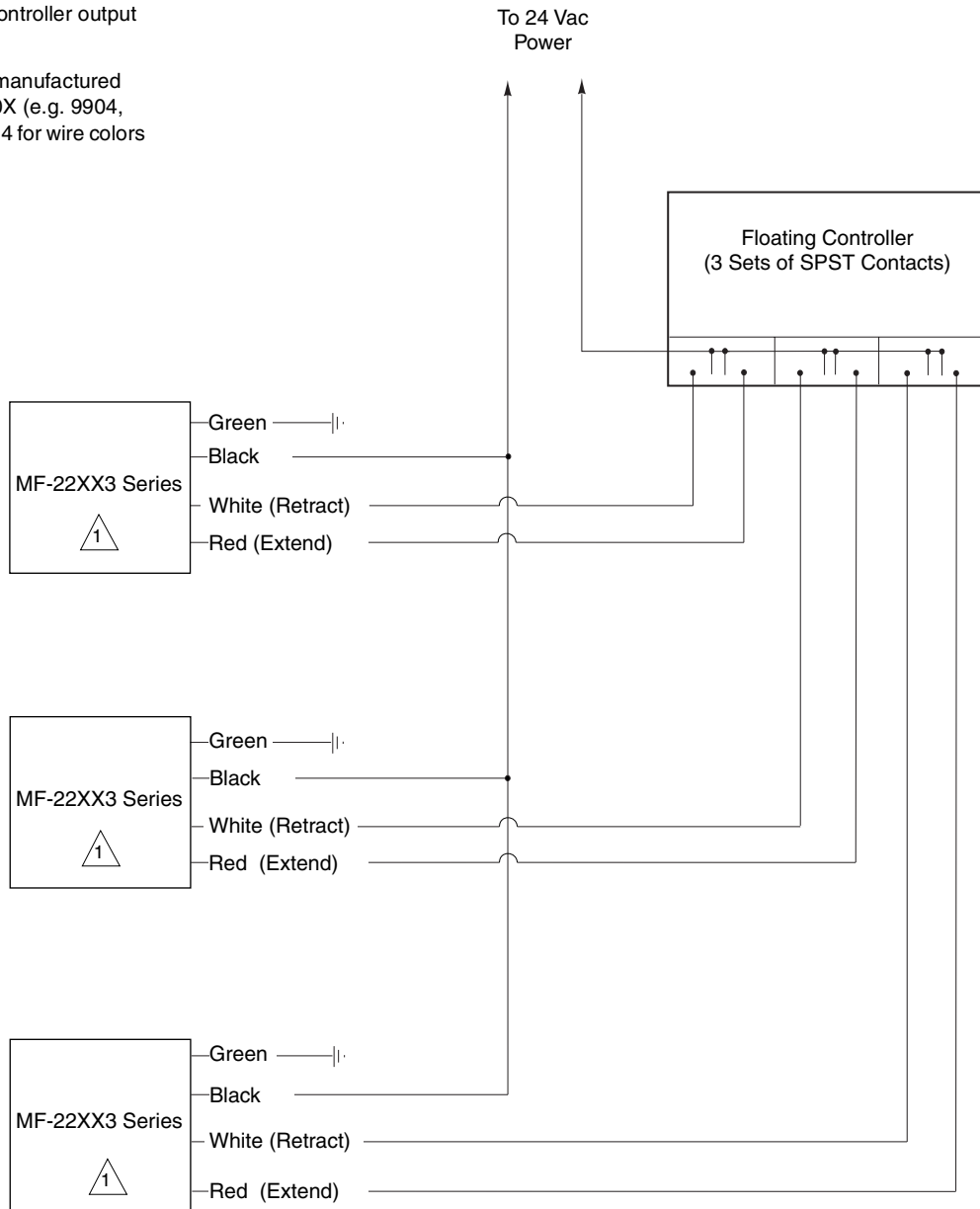

Figure-4 Typical Wiring Configuration with 3 Sets of (2) SPST Control Contacts.

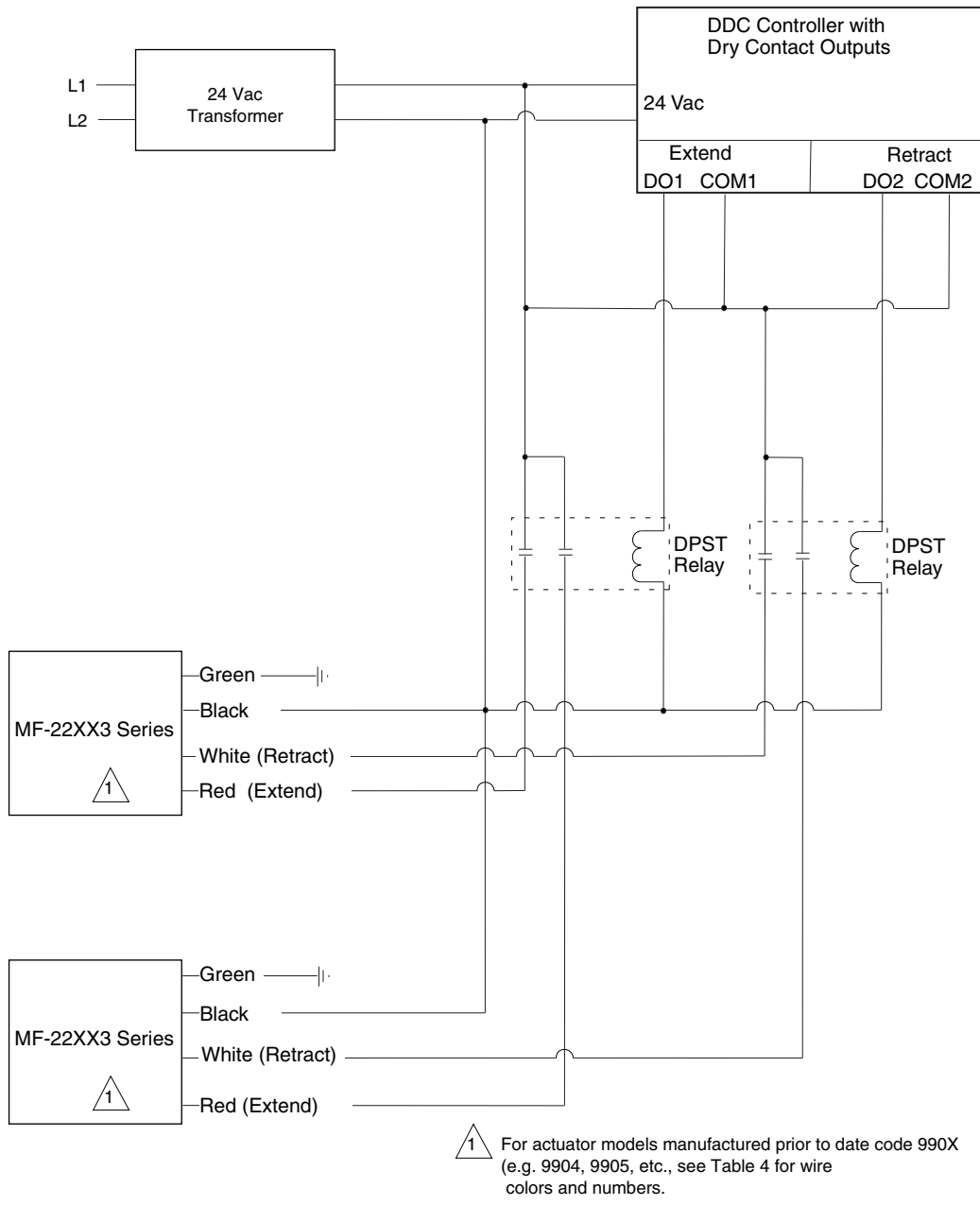
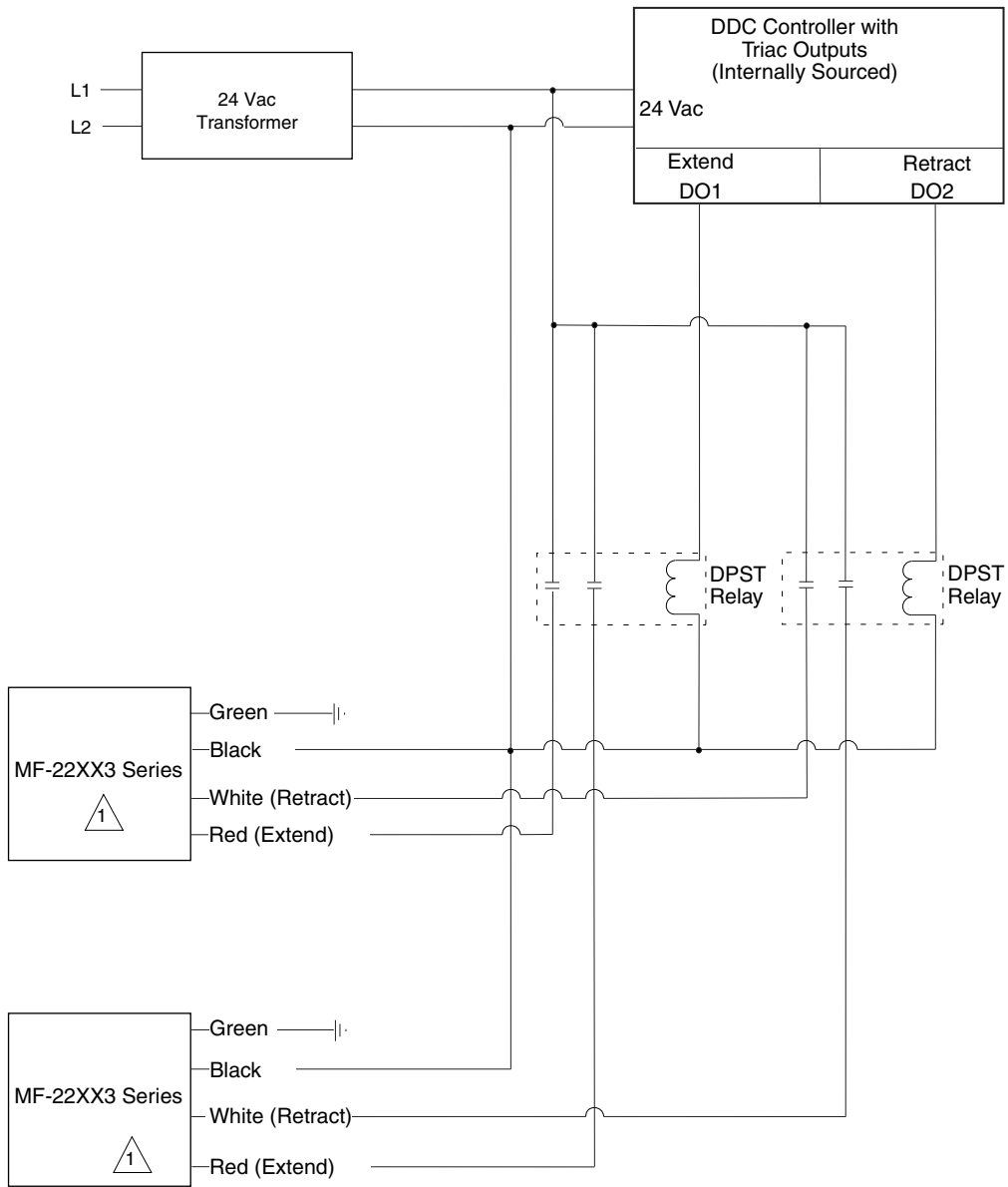

Figure-5 Wiring Configuration for Parallel Operation of Two MF-22XX3 Actuators from a DDC Controller with Dry Contact Outputs.



1 For actuator models manufactured prior to date code 990X (e.g. 9904, 9905, etc.), see Table 4 for wire colors and numbers.

Figure-6 Wiring Configuration for Parallel Operation of Two MF-22XX3 Actuators from a DDC Controller with Triac Outputs.

15K Feedback (MF-22323)

The MF-22323 contains a 15 K ohm (nominal) position feedback potentiometer (pot) to indicate the actuator's stroke position (see Figure-7 and Table-1).

Typical [9/16" (14mm) stroke] potentiometer movement is 8.5 to 91.5% of total output (exact movement on the fully retracted end varies with connected valve assembly). When used for position indication, the readout device (DDC controller) should be scaled as required if zero and 100% readouts are

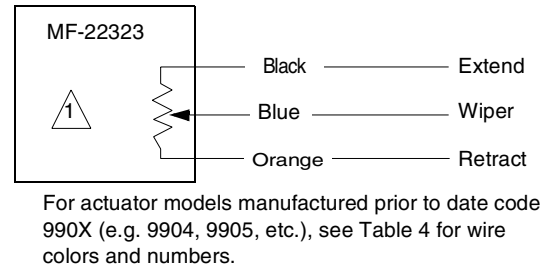
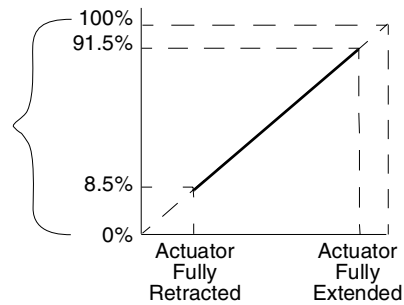

Figure-7 Feedback Potentiometer for the MF-22323.

Caution: Use the potentiometer in its intended three-wire potentiometric mode instead of in a rheostat (two-wire) mode. Consult the factory on rheostat mode.

Note: When the MF-22323 is assembled on a valve, the potentiometer will not reach 0% or 100% at the ends of valve stroke.

When used in a DDC system, the maximum voltage between brown and orange should be 24 volts AC or DC. With a voltage applied across the 15 K ohm potentiometer element, the input impedance for the blue lead must be 10,000 ohms or greater. The maximum current through the blue lead should not exceed 0.0024 amps (2.4 mA). See Figure-7.

INSTALLATION

Inspection

Inspect the package for damage. If damaged, notify the appropriate carrier immediately. If undamaged, open the package and inspect the device for obvious damage. Return damaged products.

Requirements

- Job wiring diagrams
- Tools (not provided):
 - 5/32" (4 mm) Allen wrench
 - Appropriate wrenches for stem extension and locknut
 - TOOL-37, 1-5/8" (42 mm) open-ended wrench
 - Volt-ohm meter
 - Caliper or 1/2" (12 mm) wide Scale
- Training: Installer must be a qualified, experienced technician



Warning: Disconnect the power supply (24 Vac power) before installation to prevent electrical shock and equipment damage.

Caution:

- Make all connections in accordance with the wiring diagram and in accordance with national and local electrical codes. *Use copper conductors only.*
 - Do not block the drainage slots on the threaded portion of the actuator base. Refer to Figure-10.
 - Do not remove cover of actuator. There are no user serviceable parts inside.
 - Do not exceed ratings of the device(s).
 - Avoid locations where excessive moisture, corrosive fumes, or vibration is present.
-

Mounting

Position the actuator above center line of valve to prevent damage from condensation and dripping water.

1. Allow 3" (76 mm) above the actuator valve assembly for removal and reattachment of actuator to installed valve.
2. Install all two-way valves so that they close against the flow. An arrow on the valve body or tag indicates proper flow direction.
3. Always install three-way mixing valves with two inlets and one outlet.
4. Always install three-way diverting valves with one inlet and two outlets.
5. Always install four-way Controlli valves per manufacturers instructions.
6. Valve actuators are to be mounted in any upright position above the center line of the valve body. For steam applications only, position the valve body so the valve stem and actuator are at least at 45° from vertical.

Wiring Requirements

Power and Control Leads

See Table-4 for lead identification.

Table-4 Power and Control Wiring Color Codes.

	Actuator Lead	Description	Wire Codes	
			Color Only (Current Models)	Colors with Numbers (Older Models ^a)
Actuator	Earth	Earth Ground	Green	Green (—)
	24 ^b	24 Vac	Black	Black (1)
	Extend	Extend	Red	Red ^c (2)
	Retract	Retract	White	White/Green (3)
Potentiometer	Pot. Retract	15K Feedback - Retract	Orange	White/Orange (4)
	Pot. Wiper	15K Feedback - Wiper	Blue	White/Blue (5)
	Pot. Extend	15K Feedback - Extend	Brown	White/Brown (6)

^a Actuator models manufactured prior to date code 991X (e.g. 9910, 9911, etc.) have multi-color numbered wires.

^b Black 24 Vac terminal can be connected to either side of the 24 Vac power.

^c Actuator Extend wire may be Violet on some models.

Make all electrical connections in accordance with the job wiring diagram and in compliance with national and local electrical codes. See Table-5 and Table-6 for maximum wiring lengths.

Table-5 Potentiometer Wiring Data (Leads Orange, Brown, Blue).

Wire Size (GA)	Maximum Wire Run in ft. (m) (5% voltage drop)
20	500 (152)
18	1000 (305)
16	2250 (686)
14	4000 (1219)

Caution: Use multi-conductor twisted shielded cable when it becomes necessary to install the potentiometer leads in the same conduit with power wiring or when RFI/EMI generating devices are near.

Table-6 Power and Control Wiring Data [White, ^aRed, Black, Green].

Wire Size (GA)	Maximum Wiring Run in ft. (m) (5% voltage drop)
14	5500 (1672)
16	3600 (1094)
18	2100 (638)

^a Actuator Extend wire may be Violet on some models.

Low voltage actuators installed to NEC (National Electrical Code) codes may use Class 2 wiring.

The total length of power and control wiring (black, white, or red leads) should not exceed the maximum length shown for given wire size in Table-6.

Wiring Connections

Note: Use flexible conduit only. Rigid conduit cannot be used. Actuator housing must be free to move.

Assembly/Adjustment Instructions

Caution: Damage could occur if an actuator is run or manually adjusted without being mounted to a valve. This will also cause the potentiometer output to be out of specification and will require the actuator position to be re-established. If an actuator is run or adjusted without being mounted to a valve, see “Re-establishing Potentiometer Position” below.

Re-establishing Potentiometer Position

If an actuator is run or adjusted without being mounted to a valve, the actuator position can be re-established (refer to Figure-9 and Table-4):

1. Remove actuator position indicator nut and stem extension.
2. Apply a fixed DC voltage (30 V maximum) across the potentiometer with positive voltage applied to extend [Brown] and 0 volts to retract [Orange].
3. Depress the manual override button and turn the manual override screw so that the potentiometer output is 91.5%. For example: With 10V applied across the potentiometer adjust the actuator so that the potentiometer output is 9.15 V from wiper [Blue] to retract [Orange]. Now follow the assembly steps listed below.

Actuator Assembly

See Figure-9 for parts identification.

1. Position the valve stem in the down position. Place the locknut onto the valve stem.
2. Remove the stem extension from the actuator. Screw the stem extension onto the valve stem. Adjust the stem extension of the selected actuator to the height specified for that in Figure-8. This dimension is the distance from the top of the packing nut to the shoulder of the stem extension.

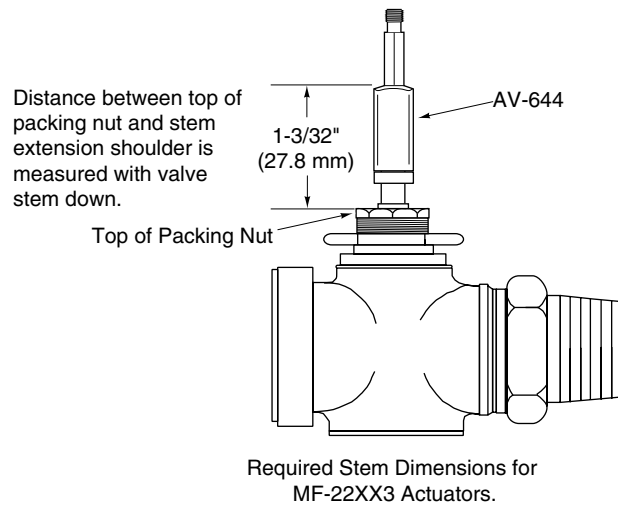

Figure-8 Valve and Stem Extension Assembly.

3. Tighten the locknut against the stem extension to make the stem extension secure to the valve stem.
4. Position the valve stem in the fully down position.

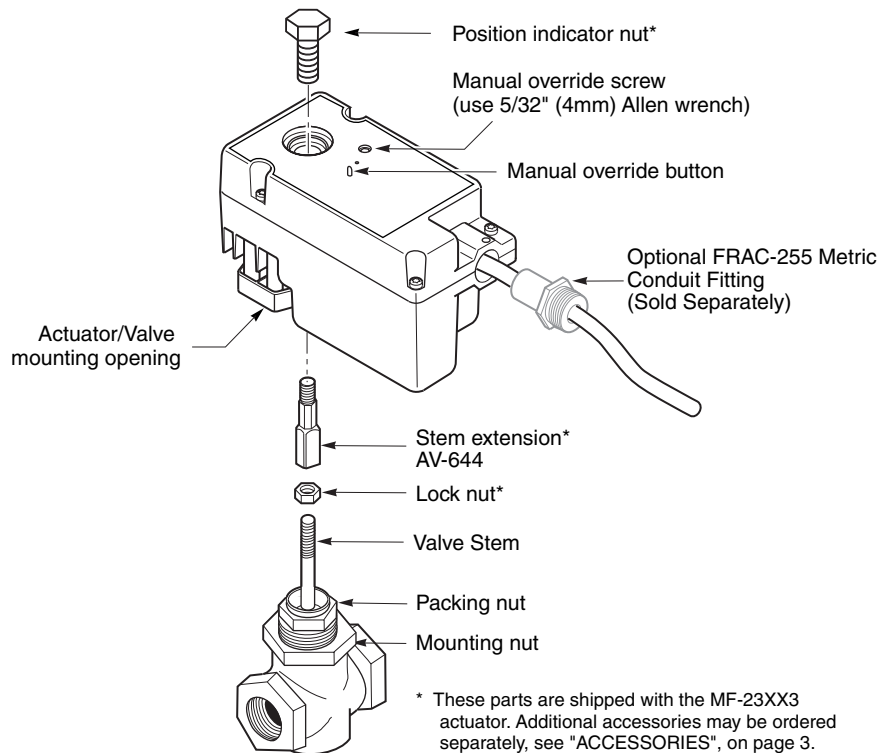

Figure-9 MF-22XX3 Assembly Diagram.

5. Confirm that the drive screw for the actuator model being mounted is the required distance from the top of the actuator case. See Figure-10. If the drive screw is not in position, insert a tapered pencil or pen into the drive screw and rotate.

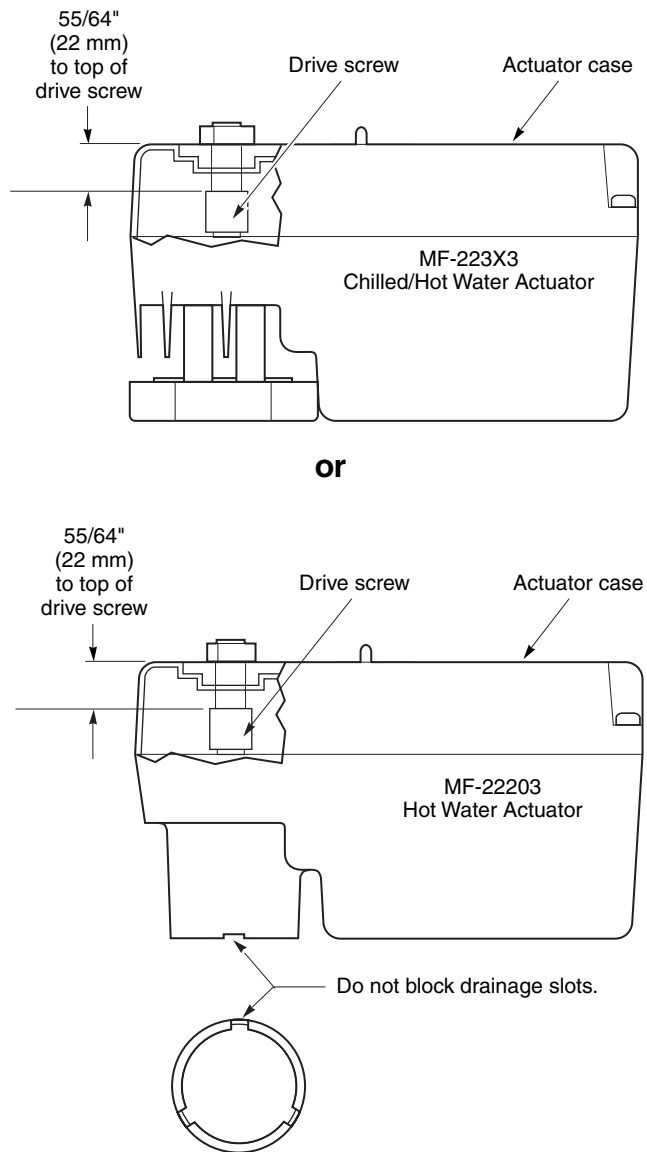

Figure-10 Proper Drive Screw Position Before Mounting.

6. Insert the valve stem extension through the bottom of the actuator. Rotate the actuator slightly until the stem extension slides through the actuator, and then rotate to the desired position for wiring.

Note: If necessary rotate the drive screw slightly to align the hex in the drive screw to the square in the bearing to match the stem extension.

7. Screw the valve mounting nut into the actuator and tighten.
8. Position the indicator nut on top of the actuator.
9. Tighten the indicator nut against the shoulder on the stem extension.

Caution: The hex shaped interface between the stem extension and drive screw does not require high indicator nut tightening torque. Do not tighten the indicator nut beyond the hex shoulder on the stem extension or a reduction in the actuator output may result. See Figure-9 for parts identification.

Manual Override Operation

All models are provided with a means of manual positioning the valve without power to the actuators. See Figure-9 for the location of the manual override button and manual override screw. Rotating manual override screw clockwise as seen from the top of the actuator, extends the actuator shaft.

1. Disengage the gear train by depressing the manual override button.
2. While holding the button turn manual override screw with 5/32" or 4 mm hex Allen wrench until the desired valve stem position is obtained, then release the manual override button.

Note: When power is applied to the actuator/valve assembly control is automatically resumed. No manual reset required

CHECKOUT

After the entire system has been installed and the actuator has been powered up, the following checks can be made for proper system operation.

Positioning with Controller

If the sensed media is within the controller's setpoint range, the actuator can be positioned by adjusting the controller setpoint up and down. Check for correct operation of valve while the actuator is being stroked.

Go, No Go Test

1. Disconnect field wiring to black, red, and white leads.
2. Apply 24 Vac to black and red leads and the actuator should extend.
3. Apply 24 Vac to black and white leads the actuator should retract.

MAINTENANCE

The actuator requires no maintenance. Regular maintenance of the total system is recommended to assure sustained optimum performance.

Note: When the MF-22323 is installed in an exceptionally dirty environment, the internal 15 k ohm feedback potentiometer may, after several years of use, exhibit some error due to contamination. The performance of the potentiometer can be restored to its original quality by manually cycling the actuator for 10 full-stroke cycles. This procedure is only necessary in those applications where normal control action does not frequently operate the actuator over its full stroke of travel.

FIELD REPAIR

Caution: Do not remove cover of actuator. No user serviceable parts inside.

Replace with a functional actuator. The AV-644 valve linkage kit can be ordered separately as a replacement part for the parts that were included with the actuator. The following instructions are for disassembling the actuator from the valve for actuator replacement or valve repacking. See Figure-9.

Disassembly Instructions

1. Turn off power to the actuator and disconnect wires at the junction box.

Warning: Disconnect the power before disassembly to prevent electrical shock.

Note: Do not remove actuator cover to disconnect wires.

2. Unscrew the position indicator nut.
3. Unscrew the mounting nut and lift the actuator from the valve.



DIMENSIONAL DATA

Dimensions for Figure-11 and Figure-12 are shown in inches with millimeters in brackets.

Note:

- Allow at least 3" (76 mm) above the actuator assembly for actuator removal ease.
- TAC Valves extend $30/64$ " (11.7 mm) into the actuator.

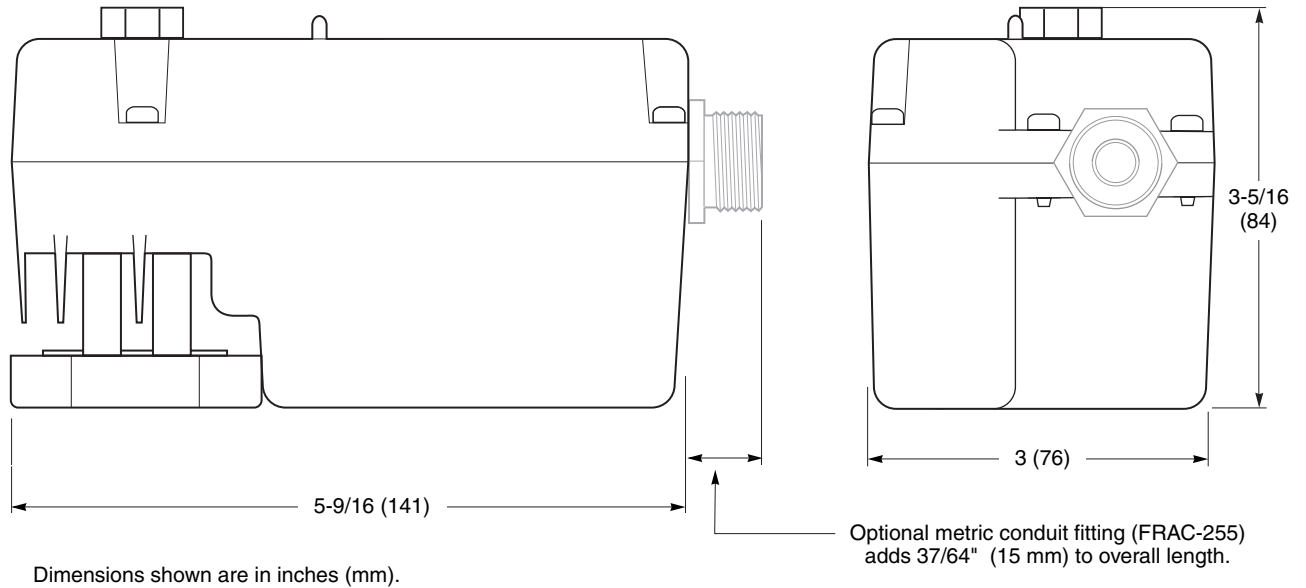

Figure-11 MF-223X3 Actuator (Chilled/Hot Water) Dimensions.

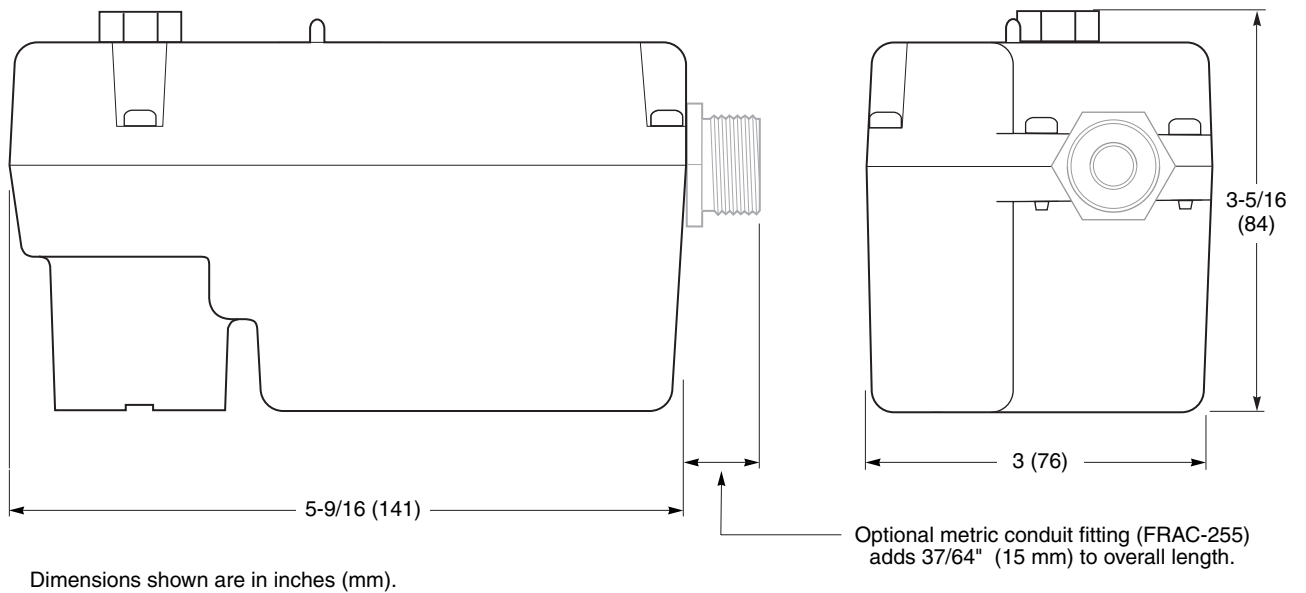

Figure-12 MF-22203 Actuator (Hot Water) Dimensions.

Copyright 2006, TAC
All brand names, trademarks and registered
trademarks are the property of their respective
owners. Information contained within this
document is subject to change without notice.

TAC
1354 Clifford Avenue
P.O. Box 2940
Loves Park, IL 61132-2940

F-26264-6



www.tac.com

