



**TAC**  
1354 Clifford Avenue  
P. O. Box 2940  
Loves Park, IL 61132-2940  
www.tac.com

## 453X Series

### *Two-Position Damper Actuator General Instructions*

### Application

The 453L, light duty damper actuators are designed for a variety of two-position, spring return, damper applications. The 453L uses a two-wire thermostat control.

The 453H, medium duty damper actuators are designed for a variety of two-position, Spring Return damper applications. The 453H uses a two-wire thermostat control.

The 453R, heavy duty damper actuators are designed for a variety of two-position, motor open and motor closed damper applications. The 453R uses a three-wire thermostat control.

### Features

- Available with end switch
- Linkage or direct drive available
- Hysteresis synchronous motor with a "lost motion" drive to protect the gear train from closing shock

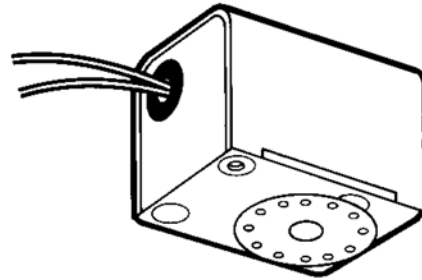

**Linkage Drive**

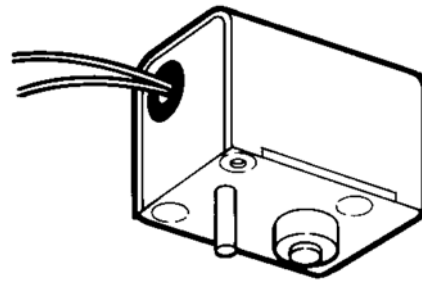

**Direct Drive**

# SPECIFICATIONS

## Inputs

**Voltage:** 24 Vac @ 50/60 Hz, 110/120 Vac @ 50/60 Hz, 220/230 Vac @ 50/60 Hz.

**Power:** See Model Chart.

**Connections:** Internal junction box, 18 in. leads, cord sets.

## Outputs

**Mechanical:**

**Optional End Switch,** 10 A @ 120 Vac.

**Direction of Rotation,** CW or CCW rotation is available.

**Linkage,** See Figure-4.

**Direct Drive,** For 5/16" maximum damper output shaft with maximum engagement of 7/8".

## Environment

**Temperature limits:**

**Shipping & Storage,** -40 to 169°F (-40 to 71°C)

**Operating,** 0 to 120°F (-17 to 49°C)

**Humidity:** Non-condensing.

**Shipping Weight:** 453L & 453H: 1.2 lbs (544 g); 453R: 1.7 lbs (771 g).

**Location:** NEMA 1.

## Agency Listings

**UL:** File # E37601.

**CSA:** File # LR19535.

**CE:** Compliant.

**Table-1 Model Chart.**

Model Number	Torque Rating in.-oz.				Power		Stroke Speed in Seconds	
	Motor Driven		Spring Return				Motor Driven	Spring Return
	0°	84°	0°	84°	W	VA		
453L	45	25	17	25	6.5	7	18 @ 60 Hz 22 @ 50 Hz	6 @ 50/60 Hz
453H	55	35	35	55	6.5	10	27 @ 60 Hz 32 @ 50 Hz	8 @ 50/60 Hz
453R	150	150	—	—	6.5	7	37 @ 60 Hz 45 @ 50 Hz	—

**Accessories**

453-52 6-12 in. damper shaft kit.

453-69 12-20 in. damper shaft kit.

453-239 Damper shaft adapter converts direct coupled shafts from 5/16 to 1/2 in.

# TYPICAL APPLICATION

## Wiring

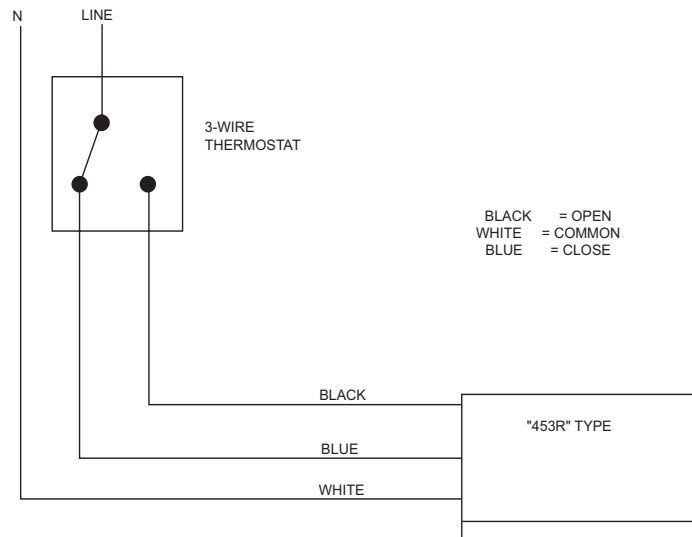

Figure-1 Typical Wiring With Three-Wire Thermostat.

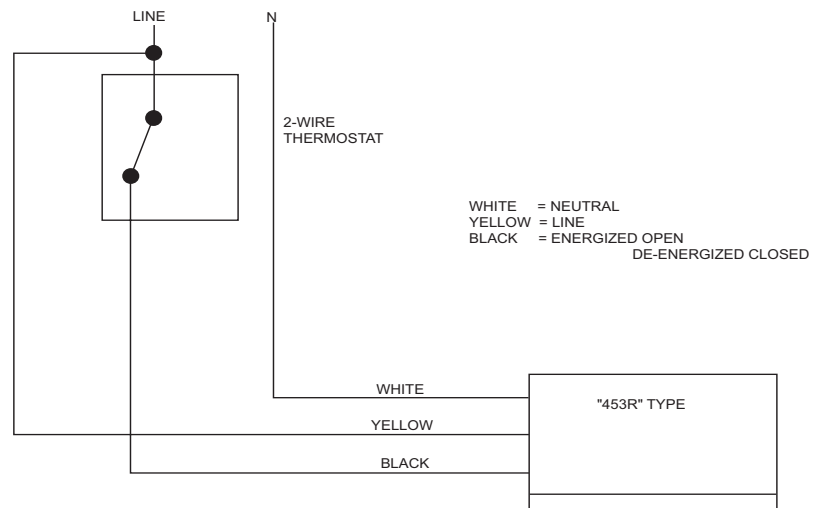

Figure-2 Typical Wiring With Two-Wire Thermostat.

## INSTALLATION

### Inspection

Inspect the package for damage. If damaged, notify the appropriate carrier immediately. If undamaged, open the package and inspect the device for obvious damage. Return damaged products.

### Requirements

- Tools (not provided)
  - 7/32" Hex wrench
  - #2 Phillips screwdriver
- Training: Installer must be a qualified, experienced technician
- Other accessories as appropriate

## Two Position Spring Return Valves

0 4 5 3 X X X X X X X X X

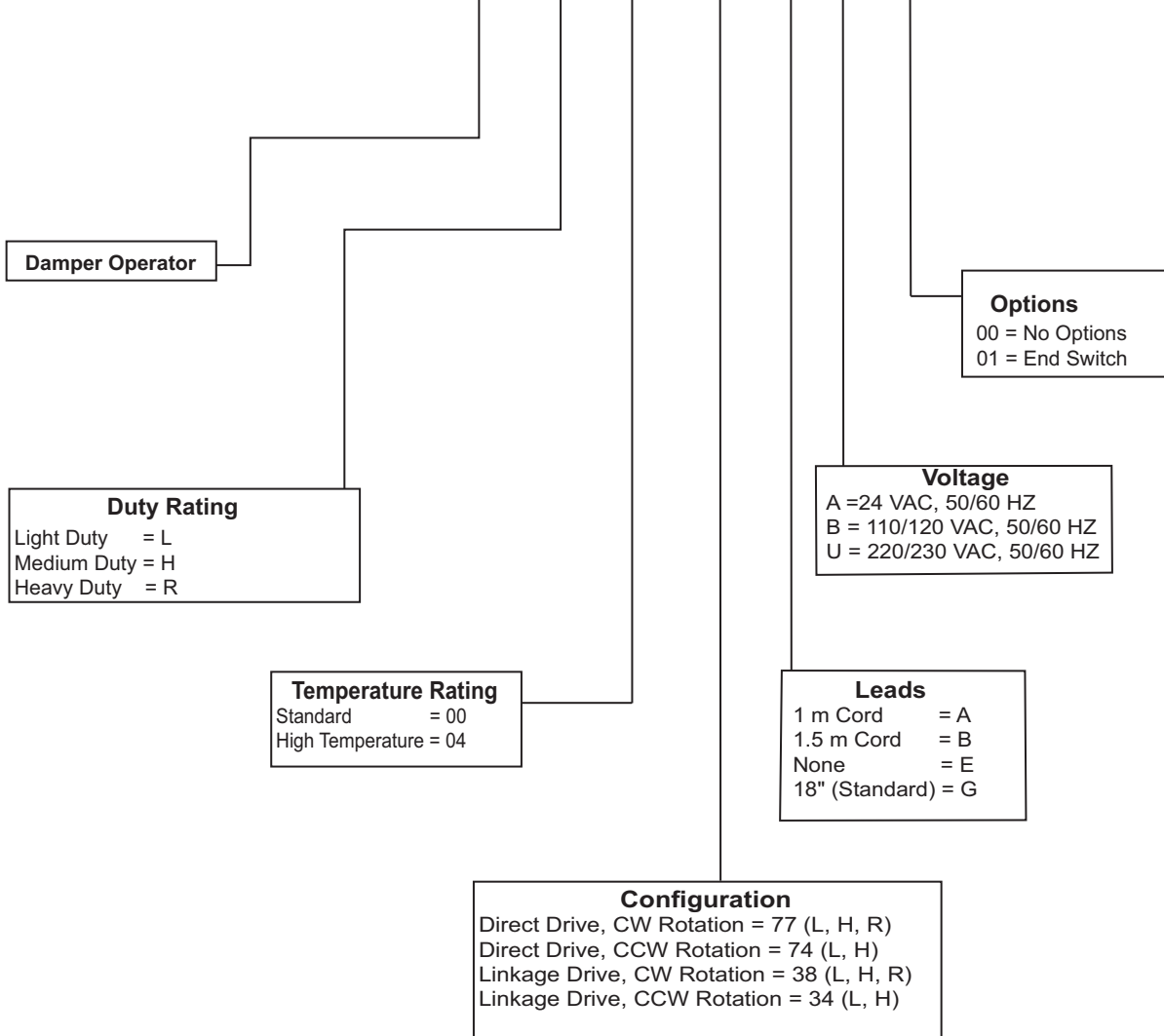

Figure-3 Ordering Chart.

## Precautions

### General

---

**▼WARNING**

---

- Electrical shock hazard! Disconnect power before installation to prevent electrical shock or equipment damage.
  - Make all connections in accordance with the electrical wiring diagram and in accordance with national and local electrical codes.
- 

---

**▼CAUTION**

---

- Avoid locations where excessive moisture, corrosive fumes, explosive vapors, or vibration are present.
  - Avoid electrical noise interference. Do not install near large conductors, electrical machinery, or welding equipment.
- 

### Federal Communications Commission (FCC)

---

**NOTE**

---

This equipment has been tested and found to comply with the limits for a Class B digital device, pursuant to Part 15 of the FCC Rules. These limits are designed to provide reasonable protection against harmful interference in residential installations. This equipment generates, uses, and can radiate radio frequency energy and may cause harmful interference if not installed and used in accordance with the instructions. Even when instructions are followed, there is no guarantee that interference will not occur in a particular installation. If this equipment causes harmful interference to radio and television reception—which can be determined by turning the equipment off and on—the user is encouraged to try to correct the interference by one or more of the following measures:

- Reorient or relocate the receiving antenna.
  - Increase the separation between the equipment and receiver.
  - Connect the equipment to an outlet on a circuit different from that to which the receiver is connected.
  - Consult the dealer or an experienced radio/television technician for help.
- 

### Canadian Department of Communications (DOC)

---

**NOTE**

---

This class B digital apparatus meets all requirements of the Canadian Interference-Causing Equipment Regulations.

Cet appareil numérique de la classe B respecte toutes les exigences du Règlement sur le matériel brouilleur du Canada.

---

### European Standard EN 55022

---

**▼WARNING**

---

This is a class B (European Classification) product. In a domestic environment this product may cause radio interference in which case the user may be required to take adequate measures.

---

## Mounting

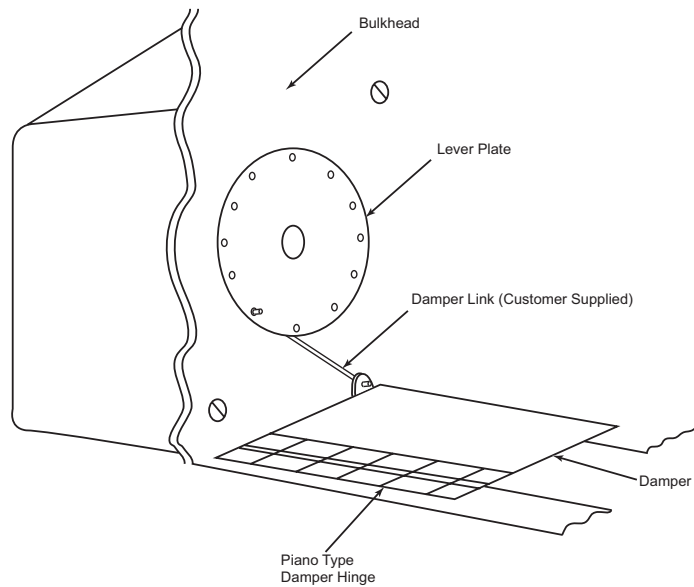

Figure-4 453X Actuator Linked to Damper.

### **Normally Open Damper (Linkage Drive Actuator)**

1. Manually place damper in the full open position.
2. Place shaft into bulkhead.
3. Secure actuator to bulkhead.
4. Attach lever plate using cotter pin.
5. Attach damper link with damper in the fully open position.

### **Normally Closed Damper (Linkage Drive Actuator)**

1. Manually place damper in the full open position.
2. Place shaft into bulkhead.
3. Secure actuator to bulkhead.
4. Apply power to the actuator and allow the actuator to drive to full rotation.
5. Attach lever plate using cotter pin.
6. Attach damper link with damper in the fully open position.
7. Remove power from the actuator.

### **Normally Open Damper (Direct Drive Actuator)**

1. Manually place damper in the full open position.
2. Slide actuator over the shaft with the anchor stud in anti-rotation hole.
3. With the hex wrench, tighten the set screw on the damper shaft.

### **Normally Closed Damper (Direct Drive Actuator)**

1. Manually place damper in the full open position.
2. Apply power to the actuator and allow the actuator to drive to full rotation.
3. Slide actuator over shaft with the anchor stud in anti-rotation hole.
4. With the hex wrench, tighten the set screw on the damper shaft.
5. Remove power from the actuator.

## CHECKOUT

After the entire system has been installed and the actuator has been powered up, the following check can be made for proper system operation. Check for correct operation of the damper while actuator is being stroked.

1. Apply power to the actuator. The actuator and the damper should be driven to their powered position.
2. If the actuator is equipped with an optional auxiliary switch, check for correct switch operation.
3. Break power to the actuator. The actuator and the damper should return to their normal spring return position.

## THEORY OF OPERATION

The 453 Series damper actuators can be directly mounted or linkage mounted on to the dampers. The 453L and 453H actuators provide spring return operation for many smaller damper applications. The 453R actuator provides a non-spring return operation for small to mid size damper applications. Using a synchronous motor, and a gear reduction of 7.2 to 1 (9.9 to 1 for the 453R Series), these actuators provide 84° of travel.

The 453L and 453H actuators are available with an optional built in auxiliary SPDT end switch to control outside resources such as fan start-up.

When the 453L and 453H actuators are powered the actuator moves to the powered position, against the spring return system. When the power is removed the spring returns the actuator to the normal position.

## MAINTENANCE

The 453 series requires no maintenance. Replace defective modules

Regular maintenance of the total system is recommended to assure sustained, optimum performance.

## FIELD REPAIR

Replace any damaged or failed components with functional replacements.

# DIMENSIONAL DATA

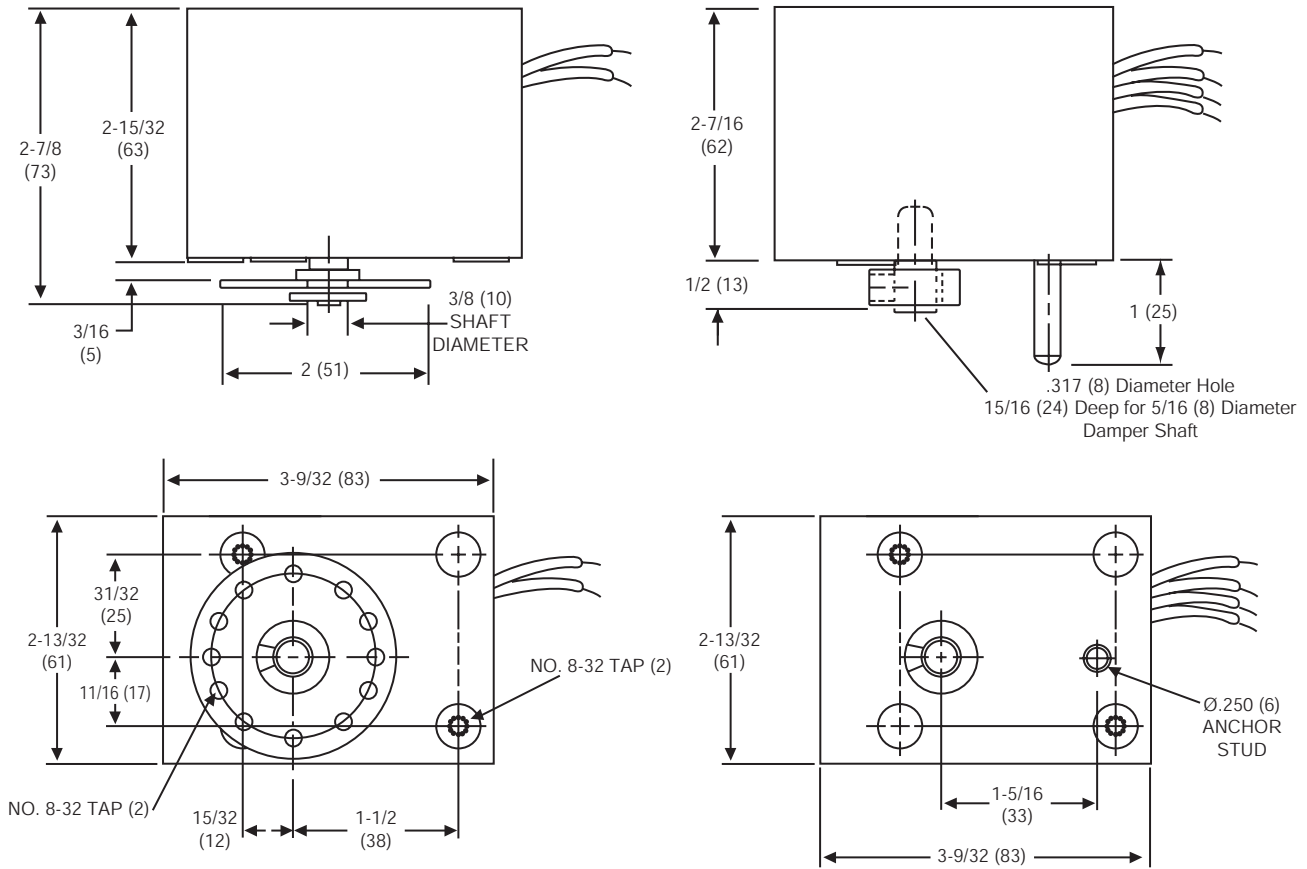

Figure-5 453L & 453H Dimensions.

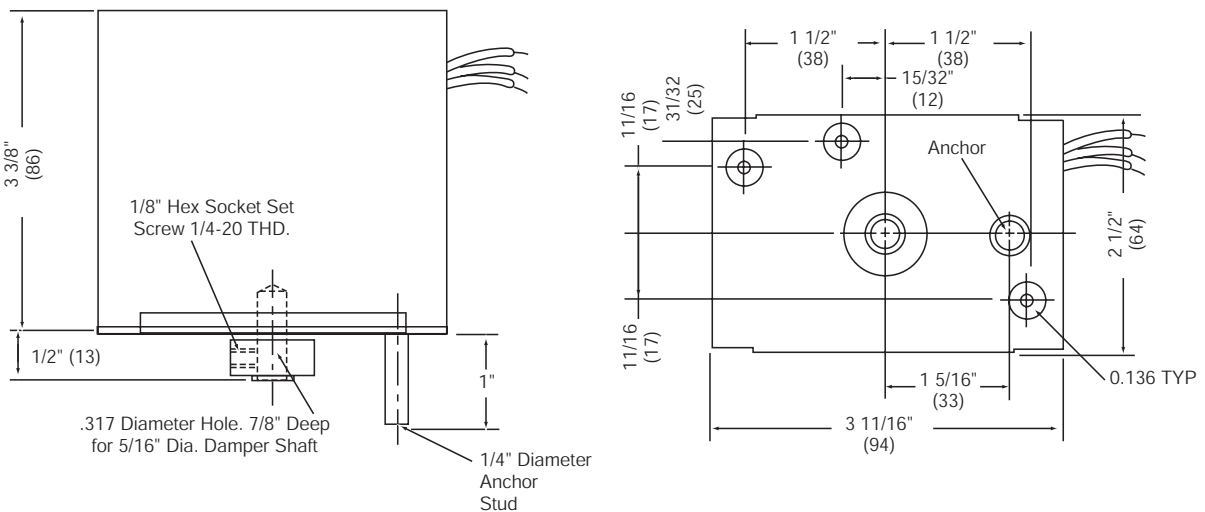

Figure-6 453R Dimensions.

Copyright 2006, TAC  
 All brand names, trademarks and registered trademarks are the property of their respective owners. Information contained within this document is subject to change without notice.

**TAC**  
 1354 Clifford Avenue  
 P.O. Box 2940  
 Loves Park, IL 61132-2940

F-27028-1



www.tac.com

